



witt lining systems

We can line anything.

P.O. Box 488
Claremore, OK 74018
918.342.0083 TEL
918.342.3932 FAX
WITTLINERS.COM

Witt Lining Systems

Specification for Flexible PVC Liner

General

1.01 Scope of Work

Furnish and/or install flexible membrane lining in the areas shown on drawings. All work shall be done in accordance with the project drawings, these specifications and membrane lining fabricator's approved shop drawings. Flexible liners will be fabricated to fully cover tank, including appurtenances, as required in the project, and shown on the drawings.

1.02 Products

The extruded lining sheet material shall be Spectra Blue® PVC as provided by Witt Lining Systems (2211 E.L. Anderson Blvd. Claremore, OK 74018, 1-800-323-3335), with the following physical specifications:

PROPERTIES Typical Values Standards

Hardness "A" (Inst./ 15 Sec. +/- 3) 91/85 ASTM D-2240

Specific Gravity (+/-0.02) 1.23 ASTM D-792

Tensile Strength 2,300 PSI ASTM D-638

Ultimate Elongation 350 % ASTM D-638

Brittleness Temperature - 20°C ASTM D-746

Temperature Rating 65°C

These datum, which are believed to be reliable, are published for information use only as it is rarely possible to duplicate actual operating conditions in laboratory testing. Consequently, no guarantee, explicit or implied, is given that similar results will be obtained in actual operating conditions.

1.03 Submittals

The fabricator of panels used in this work shall prepare shop drawings with a proposed panel layout to cover the liner area shown in the project plans. Shop drawings shall indicate the direction of factory seams and shall show panel sizes consistent with the material quantity requirements of 1.01. Details shall be included to show the termination of the panels at the perimeter of lined areas, the methods of sealing around penetrations, and methods of anchoring. Fabrication of the lining shall not commence until the shop drawings and details have been approved by the owner, or his representative.

1.04 Factory Fabrication

The individual liner widths shall be factory fabricated into large sheets custom designed for this project so as to minimize field seaming and the liner shall be fabricated in one homogenous piece if allowable. The number of factory seams must exceed the number of field seams by a factor of at least 10. An overlap seam done by RF welding is recommended. The cut membrane sheets will be factory seamed, and custom designed for the specific project so as to minimize scrap material. The following practices will be an integral part of the fabrication process:

- a) The factory seam process will typically be accomplished by the use of a dielectric welding machine. The weld will have a minimum overlap width of one-half inch.
- b) All corners, edges and bends will be performed by a dielectric creasing machine. **Liners built without creased corners and angles will not be accepted.**
- c) Each individual strip of material is numbered to correspond with shop fabrication drawings to assure accurate size.



witt lining systems

We can line anything.

1.05 Inspection and Testing of Factory Seams

The fabricator shall monitor each linear foot of seam as it is produced. Upon discovery of any defective seam, the fabricator shall stop production of panels used in this work and shall repair the seam, and determine and rectify the cause of the defect prior to continuation of the seaming process. Upon request the fabricator must provide a Quality Control procedure to the owner or his representative, which details his method of visual inspection and periodic system checks to ensure leak-proof factory fabrication.

1.06 Certification and Test Reports

Prior to installation of the panels, upon request the fabricator shall provide the owner, or his representative, with written certification that the factory seams were inspected in accordance with Section 1.05.

1.07 Panel Packaging and Storage

Factory fabricated liners shall be folded, or rolled, into a sturdy triple wall box or crate and be designed to be moved by a forklift or similar equipment. Liners which have been delivered to the project site shall be stored in a covered, heated, dry area.

1.08 Qualifications of Suppliers

The fabricator of the lining shall be experienced in the fabrication of flexible membrane lining with a minimum of 10 years of fabrication experience. Installer of lining system shall provide documentation establishing their acceptance by the fabricator. Installation of lining system by a non-authorized installer will void any warranty provided by the lining fabricator.

1.09 Subgrade Preparation by Others

Lining installation shall not begin until a proper base has been prepared to accept the membrane lining. Foreign materials and protrusions shall be removed, and all cracks and voids shall be filled and the surface made level, or uniformly sloping as indicated on the drawings. The prepared surface shall be free from loose earth, rocks, rubble and other foreign matter. Generally, no rock or other object larger than USCS sand (SP) should remain on the subgrade in order to provide an adequate safety factor against puncture. Geotextiles may be used to compensate for irregular subgrades. The subgrade shall be uniformly compacted to ensure against settlement. The surface on which the lining is to be placed shall be maintained in a firm, clean, dry and smooth condition during lining installation.

1.10 Lining Installation

Prior to placement of the liner, the installer will indicate in writing to the owner or his representative that he believes the subgrade to be adequately prepared for the liner placement. The lining shall be placed over the prepared surface in such a manner as to assure minimum handling. Materials, equipment or other items shall not be dragged across the surface of the liner, or be allowed to slide down slopes on the lining. Equipment that either heats to temperatures above 150°F or produces a heated output shall not be in contact with the liner. All parties walking or working upon the lining material shall wear soft-sole shoes. Lining sheets shall be closely fit and sealed around inlets, outlets and other projections through the lining. Liner will be anchored to the substructure as shown on the engineering drawings (Wittclips™, Koroseal® Rib-Lok™ embed strip or compression strips see Addendum A). All piping, structures and other projections through the lining shall be sealed with approved sealing methods.

1.11 Field Seaming

The surface of the welded areas must be dry and clean. Pressure must be applied to the full width of the seam on the top and bottom surface while the welded area is still in a melt-type condition. The bottom welding surface must be flat to insure that the entire seam is welded properly. Enough heat shall be applied in the welding process that a visible bead is extruded from both edges being welded. The bead insures that the material is in a melt condition and a successful molecular bond between the two surfaces is accomplished. Welding temperature is not to exceed DVS standards for the particular material being welded. Two-inch overlapped seams must withstand a minimum of 240 pounds per inch width dead load at 70° F. and 120 pounds per inch width at 160° F. as outlined in ASTM D 751. All requirements of Section 1.04 and 1.05 apply. A visible bead should be extruded from the hot air welding process. Field fabrication of corners, bends, creases, etc. will not be allowed.



witt lining systems

We can line anything.

1.12 Inspection

Inspection of the installed liner to be completed in a four stage process – visual, mechanical, high voltage spark test, infrared scan (IR scan). The visual inspection will look for any major damage or concerns that are in need of repair. The mechanical inspection will include probing and peel testing all field seams for damage or loss of integrity. The high voltage spark test will be done on the field seams liner to check for pin holes and other very fine damage or leak. The IR scan will be used to check weld integrity, weld width, factory seam density, and to ensure no liquid is behind the lining containment. Following the inspection a report will be generated detailing all problems and issues found, if no issues are found report will detail only the approximate additional life expectancy. Any and all leaks shall be repaired in accordance with section 1.13.

1.13 Patching

Any repairs to the lining shall be patched with the lining material. The patch material shall have rounded corners and shall extend a minimum of two inches (2") in each direction from the damaged area.

Seam repairs or seams which are questionable should be cap stripped with a 1" wide (min.) strip of the liner material.

The requirements of Section 1.11 apply to this cap stripping. Any repairs shall be inspected for integrity as under Section 1.12.

1.14 Warranty

Witt Lining Systems standard warranty shall apply.

See Addendum A on next page for further information.



witt lining systems

We can line anything.

Addendum A Termination methods

Wittclips™

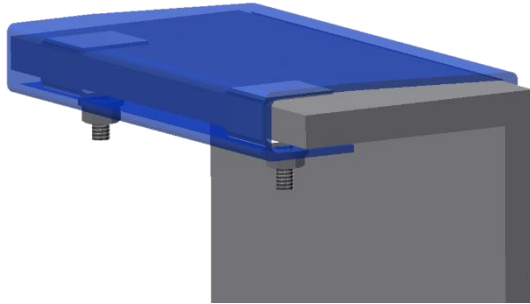

Instructions:

1. Pass the stud of the Wittclip through the back side of the pre-punched holes and attach the washer and nut.
2. Attach clips to the tank rim beginning in the corners and working towards the middle of the tank.
3. Pulling up on the sidewalls of the liner will provide slack to help get the clip on the tank rim.

Need more information? View our instructional [Wittclip™ Installation video](#).

Riblok Embed Strip

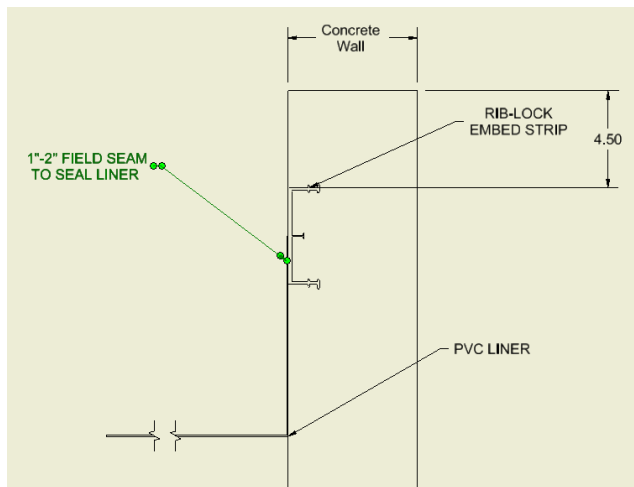

Compression Strips

